

Entatool

HP-A

Uses

Anti-vibration bases are designed for the installation of non-embedded heat pump and AC outdoor units, either on the ground or on roofs with a maximum slope of 5%. The base provides exceptional stability and multi-stage adjustability, allowing installation of a wide range of standard units on different types of ground.

Product description

- Suitable for equipment with a maximum size of 930x520mm (widthxdepth).
- Adjustable base height in the range of 456-465 mm by M10 screws.
- Adjustable horizontal crossbar ensures that the base spacing can be continuously adjusted to a width between 680-930 mm.
- The base perfectly reduces any noise caused by equipment vibration due to the specially designed use of large feet made of SBR recyclable rubber, and EPDM rubber gaskets.
- Maximum load capacity: 360 kg.
- Anti-corrosion protection ensures that the product can maintain a long and good appearance.

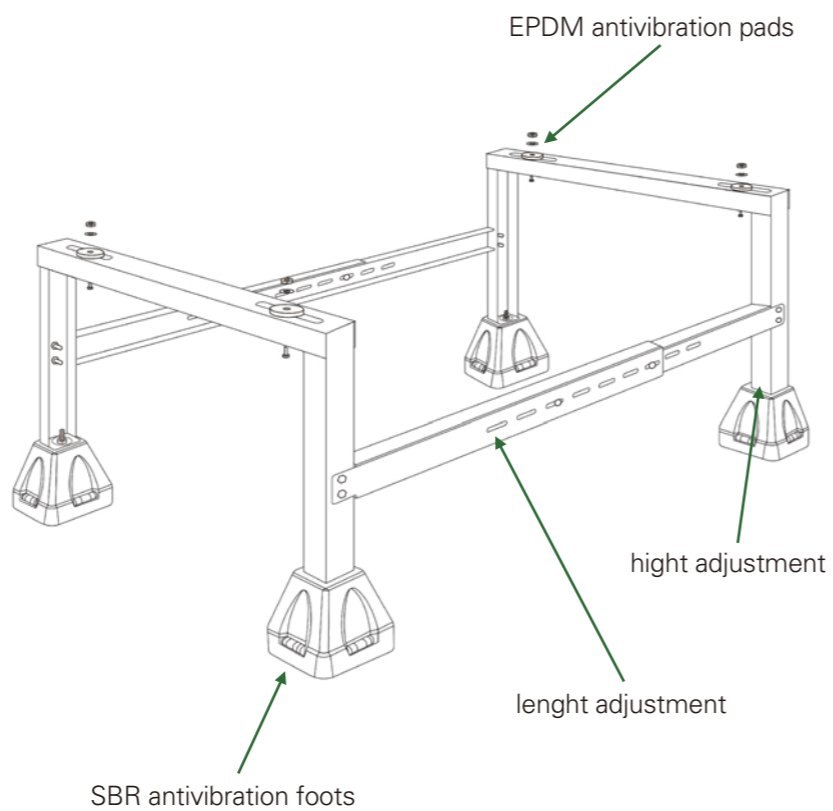

Entatool

HP-A

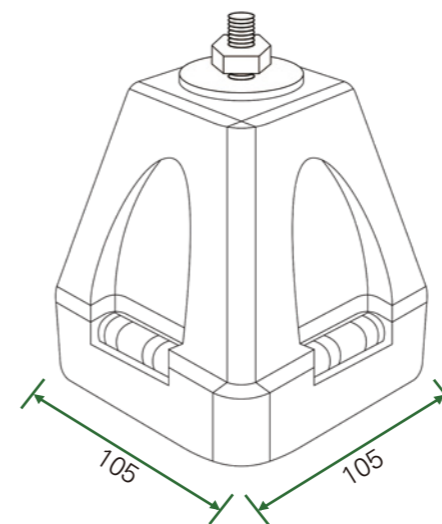
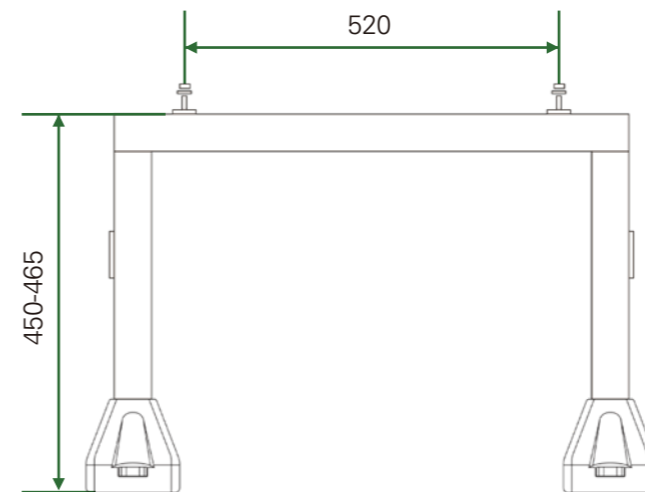
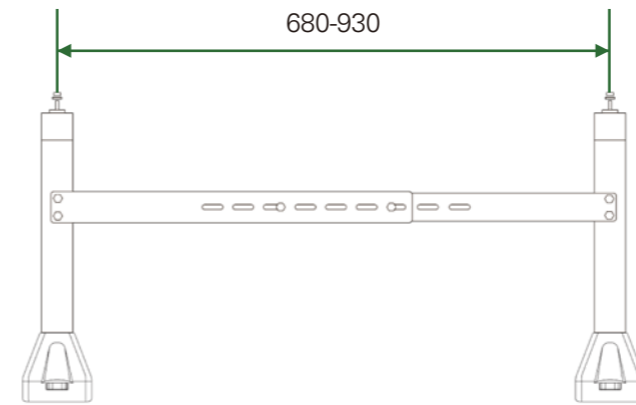

Frame construction

- Galvanized steel and powder coated in color RAL7021 - other colors can be customized upon request.
- All connectors and bolts are made of Q235 Galvanized steel.

Big Rubber Foot

- Made of SBR rubber with steel inserts.
- Feet 105x105mm.
- Standard color: black.
- Working temperature: - 40°C to 100°C.
- Allowable load: 150kg/per 1ft.

